

---

**GenBox Mini Blot Module**

Cat No: L00781

Version 12122018

---

I	General Information .....	2
	1.1 Specifications .....	2
	1.2 Safety Instruction .....	3
II	GenBox Mini Blot Module Assembly and Preparation for Transfer .....	3
	2.1 GenBox Mini Blot Module Components .....	3
	2.2 Preparation for Blotting .....	4
	2.3 Acidic Transfers .....	6
III	Transfer Conditions .....	7
	3.1 General Guide to Transfer Buffers and Running Conditions .....	7
	3.2 Notes on Electrophoretic Transfer Conditions .....	7
	3.3 Buffer Formulation .....	8
IV	Strategies for Optimizing .....	9
	4.1 Optimizing Protein Transfer .....	9
V	Choice of Blotting Membranes .....	10
	5.1 Protein Blotting Membranes .....	10
VI	Troubleshooting Guide .....	10
	6.1 Electrophoretic Transfer .....	10
VII	Warranty Information .....	12

---

## I General Information

Notes:

- To insure best performance from the GenBox Mini Blot Module, become fully acquainted with these operating instructions before using the cell to transfer samples. Please read these instructions carefully. Then assemble and disassemble the cell completely. After these preliminary steps, you should be ready to transfer a sample.
- Please wash all GenBox Mini Blot Module components and accessories with a suitable laboratory cleaner and rinsed thoroughly with distilled water before use.

The GenBox Mini Blot Module is compatible with GenBox Mini Electrophoresis tank, which is interchangeable with the electrophoresis module. The GenBox Mini Trans-Blot module accommodates two gel holder cassettes, which is useful for blotting 2 mini PAGE gels at the same time.

### 1.1 Specifications

<b>Construction</b>	
Electrode module	Molded polycarbonate
Gel Holder Cassettes	Molded polycarbonate
Electrodes wire	Platinum wire 0.254mm diameter
<b>Gel Holder dimension</b>	
Maximum gel size	10*7.5 cm
<b>Buffer Capacity</b>	
Clean	Use mild soap and warm water to clean the electrodes, cassettes, and buffer tank. Use special care when cleaning the electrode cards. Avoid stretching or breaking the platinum wires. Do not use abrasives or strong detergents. Rinse the sponges with clean water and then in distilled, deionized water.
Chemical compatibility	Components are not compatible with chlorinated hydrocarbons (e.g. Chloroform), aromatic hydrocarbons (e.g., toluene, benzene), or acetone. Use of organic solvents voids all warranties.

### 1.2 Safety Instruction

Power to the Mini Trans-Blot cell is supplied by an external DC voltage power supply.

This power supply must be ground isolated in such a way that the DC voltage output floats with respect to ground.

The maximum specified operating parameters for the cell are:

Maximum voltage	400 VDC
Maximum power	500W
Maximum ambient temperature	45°C

## II GenBox Mini Blot Module Assembly and Preparation for Transfer

### 2.1 GenBox Mini Blot Module Components

As shown in the Figure 1, there are one electrode module (Black/Red) and two gel holder cassettes. The cassette has red side that represents anode and transparent side represents cathode. Four black sponges are packed with the holder cassettes.

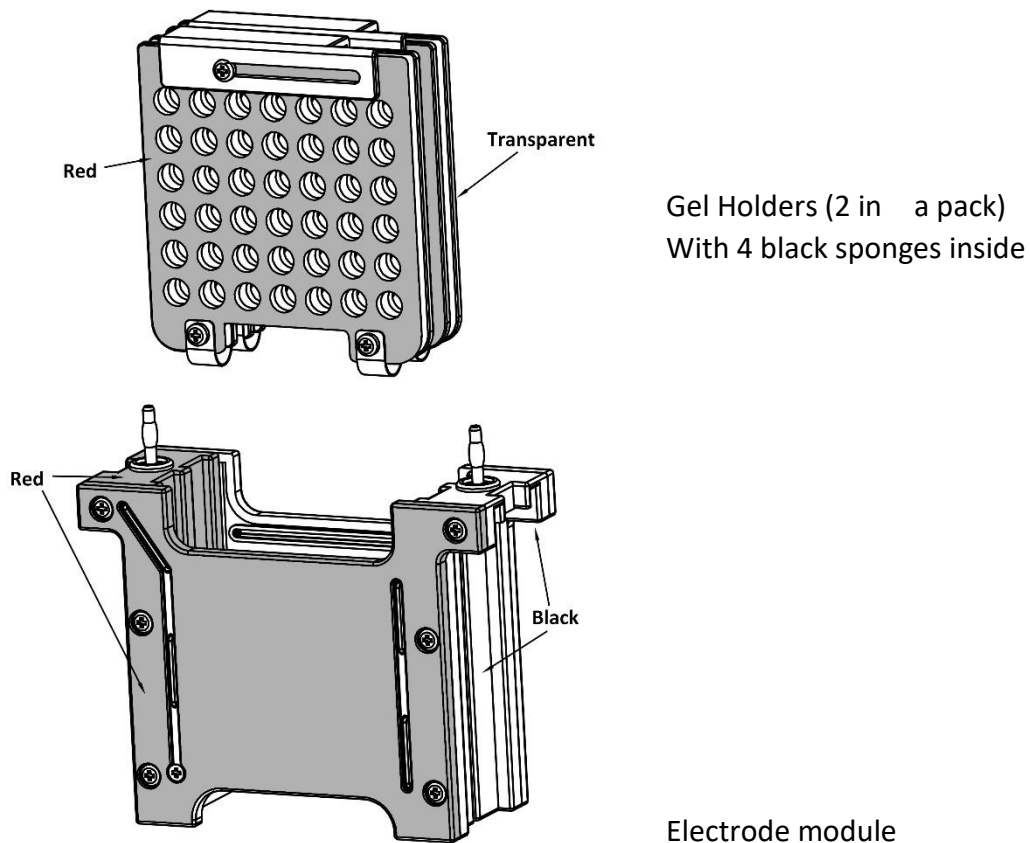

Figure 1. Components of the GenBox Mini Blot Module

## 2.2 Preparation for Blotting

### 2.2.1 Prepare the transfer buffer (Section 3.3)

Cut the membrane and the filter paper to the dimensions of the gel or use precut

membranes and filter paper. Always wear gloves when handling the membrane to prevent contamination. Equilibrate the gel and soak the membrane, filter paper, and fiber pads in transfer buffer. Active membrane (PVDF) with methanol (1 min).

### 2.2.2 Prepare the gel sandwich.

- 1) Open the cassette as shown in the figure 2.
- 2) Place the cassette with the transparent side down on a clean surface.
- 3) Place one black sponge on the transparent side of the cassette.
- 4) Place a sheet of pre-wet filter paper on the fiber pad.
- 5) Place the equilibrated gel on the filter paper. Use a glass tube or roller to gently roll out air bubbles
- 6) Place the pre-wet membrane on the gel.
- 7) Complete the sandwich by placing a piece of pre-wet filter paper on the membrane.
- 8) Add the other black sponge on the top.
- 9) Close the cassette firmly, being careful not to move the gel and filter paper sandwich. Lock the cassette closed with the white latch.

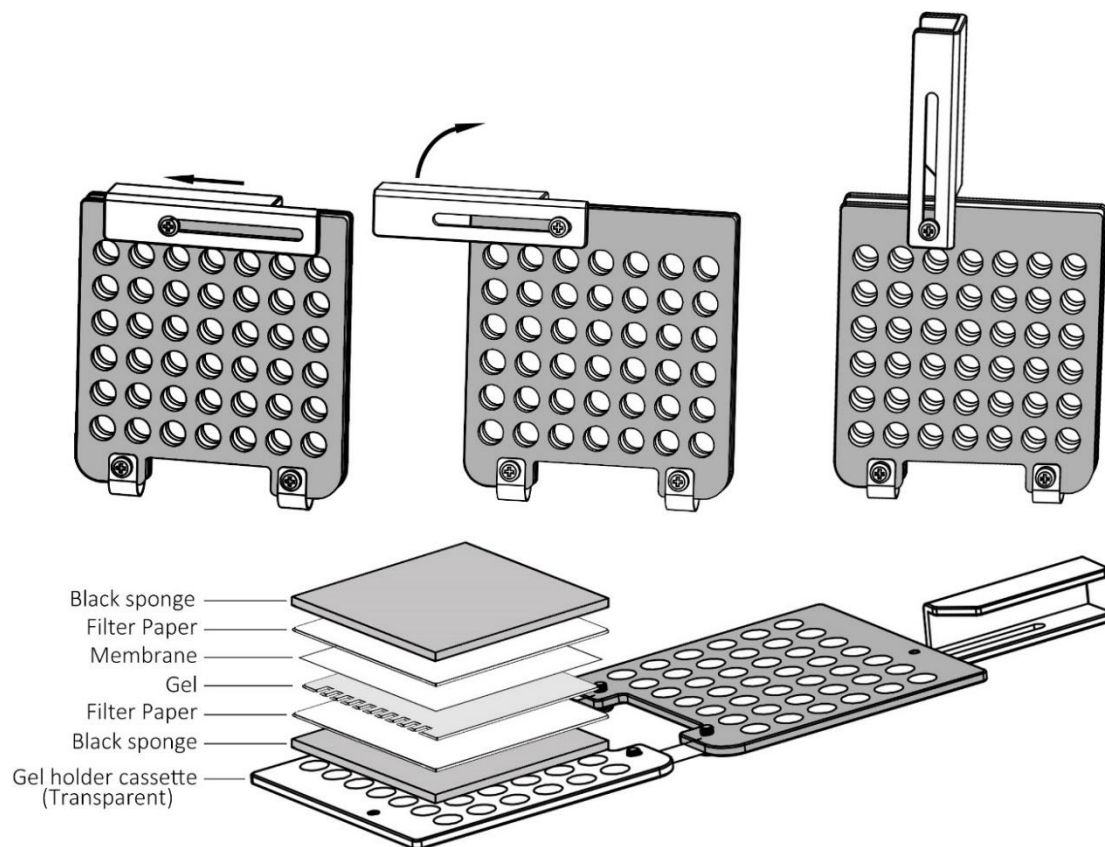

Figure 2. Assembly of Gel-Membrane Sandwich

- 10) Place the cassette into the electrode module. The red side of the cassette face to the red side of the electrode module. Repeat for the other cassette if a 2<sup>nd</sup> blotting is needed, as shown in the Figure3.

- 11) Put on the tank lid, plug the cables into the power supply, and run the blot. Refer to Section 3 for run times and voltage settings with various buffers.
- 12) The tank should be placed in one larger box, with ice and water mixed to keep the temperature of the transfer buffer low during the transfer process.
- 13) Upon completion of the run, disassemble the blotting sandwich and remove the membrane for development. Clean the cell, fiber pads, and cassettes with laboratory detergent and rinse well with deionized water.

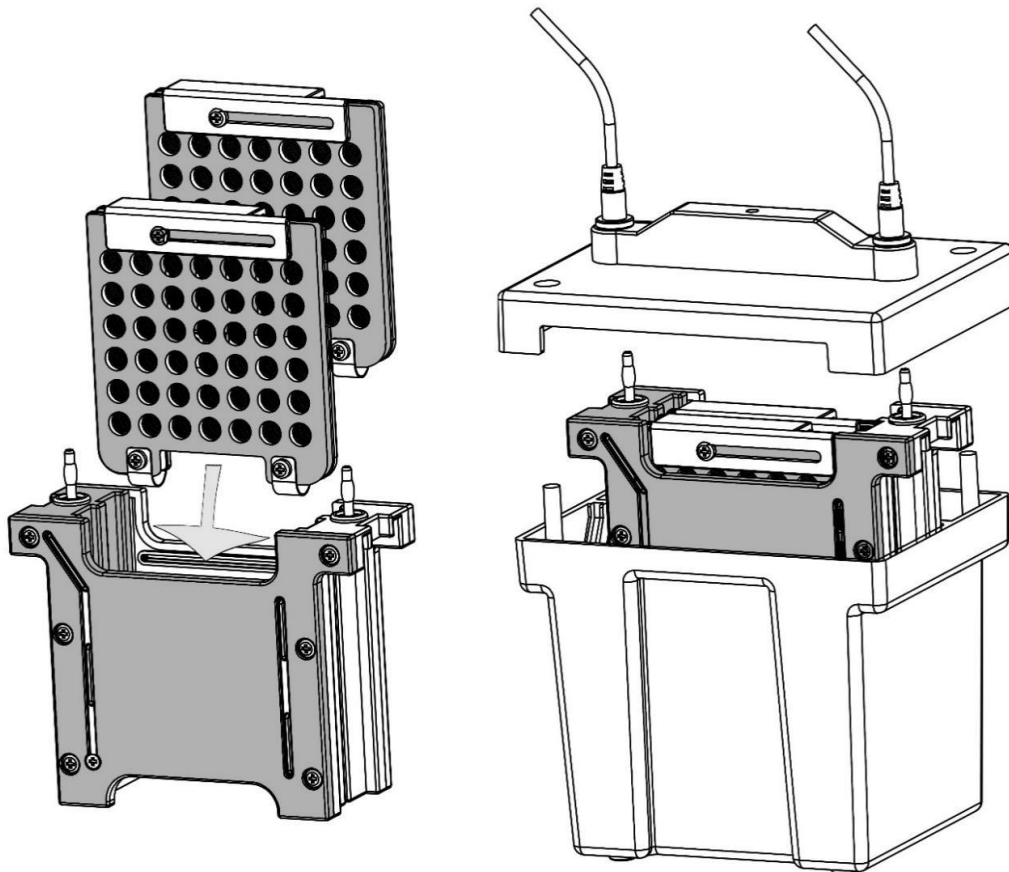

Figure 3. Place cassette into module

### 2.2.3 Acidic Transfers

If transferring under acidic conditions, switch the gel and membrane in the set up instructions. This will place the membrane on the cathode side of the gel. Under acidic conditions, proteins will transfer in the opposite direction going toward the negative cathode.

### III Transfer Conditions

#### 3.1 General Guide to Transfer Buffers and Running Conditions

Table 3.1 provides guidelines for power conditions using different buffers. Power conditions are provided for various run times. Where multiple conditions are displayed, the higher the voltage, the less time required for the run.

**Table 3.1. Guide to Buffers and Running Conditions.**

Buffer	High Intensity Field 1 Hour Transfer
SDS-PAGE Gels  A: 25 mM Tris, pH 8.3, 192 mM glycine, with or without 20% MeOH and 0.1% SDS  B: 48 mM Tris, pH 9.2, 39 mM glycine, with or without 20% MeOH and .025% ~ 0.1% SDS	100 V, constant 165mA
Native Gels  25 mM Tris, pH 8.3, 92 mM glycine. No methanol.	100 V, constant 165mA

\*Please refer to Section 2.3 before transferring.

#### 3.2 Notes on Electrophoretic Transfer Conditions.

- Alterations in buffer make-up, i.e., addition of SDS, or changes in ion concentration due to addition of acid or base to adjust the pH of the buffers.
- Gel pH, ionic strength, and percentage of acrylamide, especially if the gel has not been properly equilibrated.
- Volume of buffer; current increases when volume increases.
- Transfer temperature; current increases when temperature increases.
- Time in transfer at which reading was taken; current normally increases as the buffering capacity diminishes with progress of the run.
- **Pre-equilibration of gels (5-10 min)**

All electrophoresis gels should be pre-equilibrated in transfer buffer prior to electrophoretic transfer. Pre-equilibration will facilitate the removal of contaminating electrophoresis buffer salts and neutralization salts. If the salts are not removed, they will increase the conductivity of the transfer buffer and the amount of heat generated during the transfer.

### 3.3 Buffer Formulation

All formulas provided below are for a total volume of 1 L of buffer. Approximately 850 ml of buffer are required for the GenBox Mini Blot Module.

Do not add acid or base to adjust pH of the following buffers. Methanol should be analytical reagent grade, as metallic contaminants in low grade methanol will plate on the electrodes.

Blotting buffer recipe	Preparation
A: 25 mM Tris, 192 mM glycine, 20% v/v methanol, pH 8.3	Mix 3.03 g Tris, 14.4 g glycine, and 200 ml of methanol; add distilled deionized water (ddH <sub>2</sub> O) to 1 L.
B: 25 mM Tris, 192 mM glycine, pH 8.3	Mix 3.03 g Tris and 14.4 g glycine; add distilled deionized water ]ddH <sub>2</sub> O to 1 L.

## IV Strategies for Optimizing

### 4.1 Optimizing Protein Transfer

Gradient gels are often more effective than single gel concentrations for elution of a wide range of molecular weight proteins.

The concentration of gels is inversely proportional to the pore size, low concentration gel should be selected if the target protein is a macromolecular protein and vice versa.

#### **Transfer time adjustment**

Under constant current or voltage, blotting time can be adjusted according to the molecular of the target protein. In general, large molecular proteins require more time.

#### **Voltage adjustment**

Adjusting voltage affects the time which protein transferred to the membrane. High temperature of increasing the voltage may affect the state of protein denaturation and transfer efficiency.

#### **Add detergent**

Addition of 0.1% SDS detergent to Tris, glycine, methanol buffer has been reported to increase transfer efficiency<sup>7</sup>. However, increases relative current, power, and heating. Also, temperatures below 10°C may precipitate the SDS so the starting buffer temperature will be higher. SDS may also affect the antigenicity of some proteins. SDS will aid in eluting the proteins from the gel, but it may reduce the binding efficiency of those proteins to the membrane.

#### **Alter membrane type**

Both Nitrocellulose and PVDF membrane can be used for protein transfer.

#### **Enhance gel-membrane contact**

Poor gel-membrane contact may cause the protein fail to bind the membrane. Poor contact is usually due to excess moisture in the gel-membrane interface. Proper technique and the use of a test tube or glass pipet as a “rolling pin” should assure good contact.



## V Choice of Blotting Membranes

### 5.1 Protein Blotting Membranes

#### Nitrocellulose Membrane

Nitrocellulose membranes have been used extensively for protein binding and detection. They can be easily stained for total protein by a dye stain (Amido Black, Coomassie Blue, Ponceau S, Fast Green FCF, etc.), or the more sensitive Colloidal Gold Total Protein Stain, and also allow either RIA, FIA, or EIA. Nitrocellulose has a high binding capacity of 80–100 µg/cm. Nonspecific protein binding sites are easily and rapidly blocked, avoiding subsequent background problems. No preactivation is required. Low molecular weight proteins (especially <15,000 daltons) may be lost during post transfer washes, thus limiting detection sensitivity. Smaller pore size nitrocellulose membrane (0.2 µm), has been shown to be effective in eliminating this loss. Large proteins (>100,000 daltons) denatured by SDS may transfer poorly due to the addition of alcohol to the transfer buffer. Alcohol increases binding of SDS-proteins to nitrocellulose, but decreases pore sizes in the gel. Elimination of alcohol from SDS-protein transfers results in considerably diminished binding. Adding SDS (up to 0.1%) to the transfer buffer increases the transfer efficiency of proteins, but reduces the amount of binding to the membrane. Also, SDS increases the conductive.

#### PVDF Membrane

Polyvinylidene difluoride (PVDF) membrane is an ideal support for amino-terminal sequencing, amino acid analysis and immunoassays of blotted proteins. PVDF retains proteins under extreme conditions of exposure to acidic or basic conditions, and in the presence of organic solvents. Greater retention during sequencing manipulations enhances the likelihood of obtaining information from rare, low abundance proteins, by increased initial coupling and higher repetitive yields. In addition, PVDF membrane exhibits better binding efficiency of blotted material in the presence of SDS in the transfer buffer. PVDF must first be wetted in 100% MeOH but can then be used in buffer, which does not contain MeOH.

## VI Troubleshooting Guide

### 6.1 Transfer conditions affect the results

#### 1) Transfer time is too short

- Increase the transfer time.

#### 2) Power is too low

- Always check the current at the beginning of the run. The current may be too low for a particular voltage setting.

#### 3) The transfer buffer is contaminated or misconfigured

- The wrong proportion of buffer solution will result in poor transfer results; replace the contaminated transfer solution.

#### **4) PVDF membrane is not activated with methanol**

- The PVDF membrane must be pre-wet in methanol, the purpose of treatment with methanol is to activate the positively charged groups on the membrane to make it easier to bind to the negatively charged protein; the un-activated PVDF membrane is difficult to bind to the protein.

#### **5) Methanol in the transfer buffer is restricting elution**

- Reduction of methanol results in increased transfer efficiency of proteins from the gel, but it also diminishes binding to nitrocellulose.

### **6.2 Swirls or missing bands; diffuse transfers**

#### **1) Poor contact between the membrane and the gel, air bubbles or excess buffer remain between the blot and gel.**

- Use a test tube or pipet as a rolling pin, and roll over the membrane carefully in both directions until air bubbles and excess buffer are removed from between gel and membrane, and complete contact is established.
- Use thicker filter paper in the gel/membrane sandwich.
- Replace the fiber pads. Pads will compress with time, and will not hold the membrane to the gel.

#### **2) Power conditions are too high.**

- Always check the current at the beginning of the run. See the power guidelines for specific applications in Section 3.

#### **3) The membrane is not properly wet or has dried out.**

- White spots on the nitrocellulose membrane indicate dry areas where protein will not bind. If wetting does not occur immediately by immersion of the sheet in transfer buffer, heat distilled water until just under the boiling point, and soak the membrane until completely wet. Equilibrate in transfer buffer until ready for use.

#### **4) The gel electrophoresis may be at fault.**

- Artifacts of electrophoresis may be produced by poor polymerization, inappropriate running conditions, contaminated buffers, sample overload, etc.

### **6.3 Gel cassette pattern transferred to blot.**

#### **1) Contaminated or thin fiber pads are used.**

- Replace the fiber pads, or thoroughly clean the contaminated pads.

#### **2) Transfer apparatus is assembled incorrectly, and the proteins are moving in the wrong direction.**

- The gel/membrane sandwich may be assembled in the wrong order or the

cassette is inserted in the tank facing the opposite orientation. Check the polarity of the connections to the power supply.

#### **6.4 Poor binding to the membrane—nitrocellulose.**

**Nitrocellulose requires 20% methanol in the transfer buffer for optimal protein binding.**

- Make sure the buffer contains the proper amount of methanol. Proteins may be transferring through the nitrocellulose.

- Use PVDF (higher binding capacities) or 0.2  $\mu\text{m}$  nitrocellulose (smaller pore size). Decrease the voltage if using the high intensity option.

#### **6.5 Poor binding to the membrane—PVDF**

**The membrane may not be completely wet.**

- Because of the hydrophobic nature of PVDF, the membrane must be pre-wet in alcohol prior to equilibration in aqueous transfer buffer.

#### **6.6 Poor binding to the membrane—high molecular proteins.**

**The transfer time may be not enough.**

- The transfer speed of high molecular proteins is slower than the low molecular weight proteins, increase the transfer time could improve the phenomenon.

## **VI Warranty Information**

GenScript warrants the GenBox Mini Blot Module against defects in materials and workmanship for one year. If any defects occur in the instrument during this warranty period, GenScript will repair or replace the defective parts free.

The following defects, however, are specifically excluded:

- Defects caused by improper operation.
- Repair or modification done by anyone other than GenScript or an authorized agent.
- Use of fittings or other spare parts supplied by anyone other than GenScript.
- Damage caused by accident or misuse.
- Damage caused by disaster.
- Corrosion due to use of improper solvent or sample.

For any inquiry or request for repair service, contact GenScript after confirming the model and serial number of your instrument.

Warranty Information

Model \_\_\_\_\_ 11 \_\_\_\_\_

Catalog number \_\_\_\_\_

Date of delivery \_\_\_\_\_

Serial number \_\_\_\_\_

Invoice number \_\_\_\_\_

Purchase order number \_\_\_\_\_

GenScript US

860 Centennial Ave., Piscataway, NJ 08854

Tel: 732-885-9188, 732-885-9688

Fax: 732-210-0262, 732-885-5878

Email: [product@genscript.com](mailto:product@genscript.com)

Web: <http://www.genscript.com>

**For Research Use Only.**